

**MINI JUMBO**

**VACUUM PACKAGING MACHINE**



**FEATURES**

- Standard with 1 seal bar (front): 280 mm
- Standard double seal (two wires). Optional without extra costs: Cut-off seal
- Seal bars easily removable for cleaning and maintenance purposes
- Pump capacity: 4 m<sup>3</sup>/h Busch vacuum pump
- Pump maintenance and cleaning program
- Machine cycle: 25-60 sec
- Standard Time control with a 1 program memory
- Deep drawn stainless steel vacuum chamber
- Stainless steel exterior and transparent lid
- Comes with insert plate for a faster cycle and product adjustment

**OPTIONS**

- High lid
- Sensor control

**ACCESSORIES**

- Inclined insert plate (for packing liquids)
- Food container adaptor
- Service kit for standard maintenance
- Trolley with shelf

**DESCRIPTION**

The robust, stainless steel Mini Jumbo vacuum packaging machine is standard equipped with a Busch vacuum pump and Time control with a 1 program memory. This table-top model complies with CE standards.

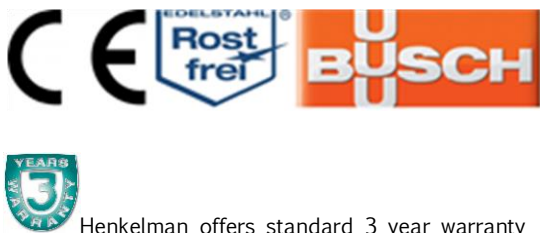

**SEAL BAR CONFIGURATION**

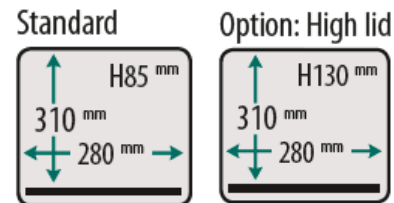

# VACUUM PACAGKING MACHINE MINI JUMBO – SPECS

VACUUM PACKAGING MACHINE MINI JUMBO – SPEC SHEET

## DIMENSIONS

In mm

OUTER DIMENSIONS  
Mini Jumbo

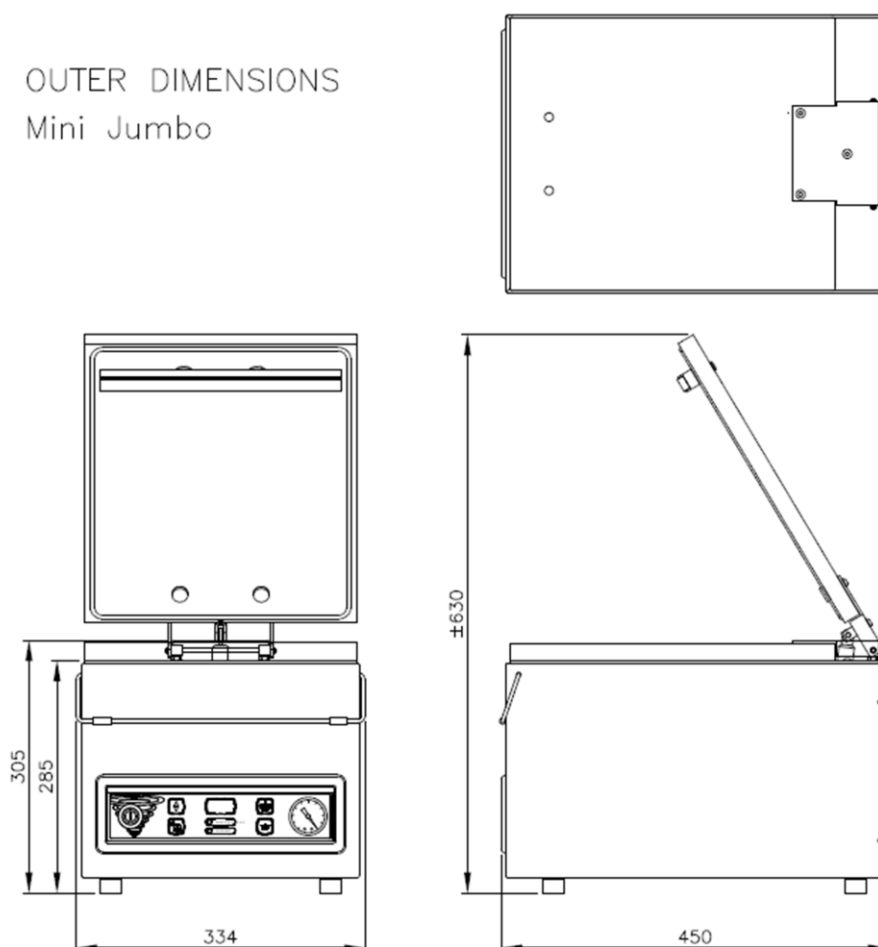

Model	Dimensions (mm)		Voltage*	Pump capacity (m <sup>3</sup> /h)	Power (kW)	Weight (kg)
	Chamber (usable space) L x W x H	Machine L x W x H				
Mini Jumbo	310 x 280 x 85	450 x 334 x 305	230V-1-50	4	0,3	26

\* Other voltages available



HENKELMAN BV  
Titaniumlaan 10  
5221 CK 's-Hertogenbosch  
The Netherlands

**Sales support**  
P +31 73 621 36 71  
E [info@henkelman.com](mailto:info@henkelman.com)  
**Service/technical support**  
P +31 73 621 36 71  
E [service@henkelman.com](mailto:service@henkelman.com)